

Dunlap Stainless, Inc.

2905 Ramsey Road

Gainesville, GA 30507

(770) 531-1933 (Mon-Fri 8am-5pm)

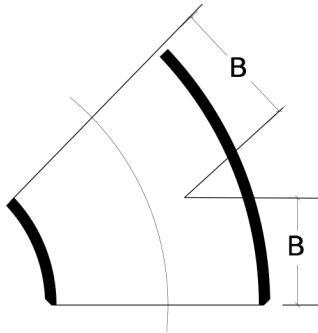

45° Elbow

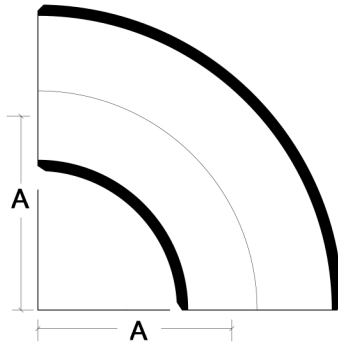

90° Elbow / Long Radius

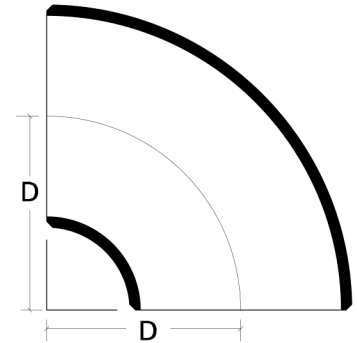

90° Elbow / Short Radius

NOM PIPE SIZE	45° Elbows			
	SCH. 5S	SCH. 10S	SCH. 40S	SCH. 80S
1/2	.06	.07	.09	.12
3/4	.06	.07	.09	.12
1	.12	.19	.25	.31
1 1/4	.19	.25	.38	.50
1 1/2	.25	.38	.50	.63
2	.31	.56	.88	1.13
2 1/2	.75	1.06	1.69	2.19
3	1.06	1.38	2.38	3.31
3 1/2	1.16	1.66	3.13	4.40
4	1.66	2.38	4.60	6.82
5	3.25	4.00	7.57	10.56
6	5.00	6.00	12.00	18.00
8	8.65	11.75	23.75	36.50
10	16.00	21.50	42.50	57.00
12	25.20	30.00	65.50	87.50
14	34.00	40.00	75.00	103.00
16	50.00	52.50	101.00	134.00
18	62.50	66.00	131.00	175.00
20	82.50	110.00	165.00	219.00
24	140.00	155.00	323.00	308.00

NOM PIPE SIZE	90° Elbows - Long Radius			
	SCH. 5S	SCH. 10S	SCH. 40S	SCH. 80S
1/2	.12	.14	.18	.23
3/4	.13	.15	.19	.25
1	.19	.30	.35	.48
1 1/4	.31	.50	.56	.88
1 1/2	.38	.69	.88	1.13
2	.64	1.13	1.56	2.00
2 1/2	1.50	1.88	3.00	4.00
3	2.00	2.69	4.81	6.56
3 1/2	2.62	3.75	6.25	8.80
4	3.31	4.75	9.19	13.63
5	6.50	8.00	15.13	21.13
6	10.00	12.00	24.00	36.00
8	17.30	23.50	47.50	73.00
10	32.00	43.00	85.00	114.00
12	51.00	60.00	131.00	175.00
14	68.00	80.00	155.00	206.00
16	100.00	105.00	202.00	269.00
18	125.00	132.00	269.00	350.00
20	165.00	220.00	330.00	439.00
24	280.00	310.00	464.00	617.00

NOM PIPE SIZE	90° Elbows - Short Radius			
	SCH. 5S	SCH. 10S	SCH. 40S	SCH. 80S
1/2	-	-	-	-
3/4	-	-	-	.25
1	.17	.23	.26	.38
1 1/4	.31	.38	.45	.63
1 1/2	.43	.49	.63	.88
2	.63	.81	1.13	1.55
2 1/2	1.25	1.35	2.25	2.88
3	1.75	2.17	3.31	4.20
3 1/2	2.35	3.05	4.54	5.35
4	3.12	3.79	6.88	9.06
5	4.94	6.12	11.63	16.10
6	7.75	9.15	17.50	26.00
8	15.44	17.63	37.60	54.80
10	27.40	35.00	63.00	99.80
12	35.00	40.00	80.00	125.00
14	44.00	52.00	101.00	135.00
16	65.00	68.00	131.00	175.00
18	81.00	86.00	175.00	228.00
20	107.00	143.00	215.00	285.00
24	182.00	202.00	302.00	401.00

Dunlap Stainless, Inc.

2905 Ramsey Road

Gainesville, GA 30507

(770) 531-1933 (Mon-Fri 8am-5pm)

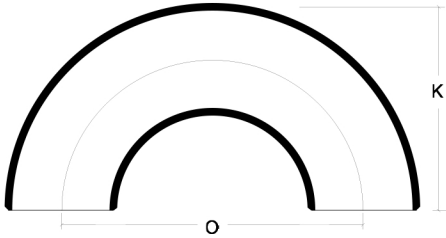

180° Return / Long Radius

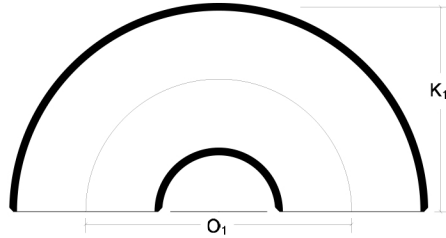

180° Return / Short Radius



Eccentric Reducer

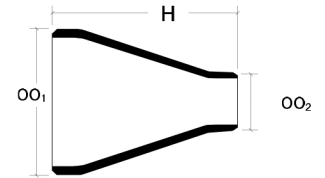

Concentric Reducer

NOM PIPE SIZE	180° Returns - Long Radius			
	SCH. 5S	SCH. 10S	SCH. 40S	SCH. 80S
1/2	.21	.26	.34	.43
3/4	.30	.41	.50	.69
1	.53	.75	.76	1.38
1 1/4	1.00	1.26	1.66	2.50
1 1/2	1.28	1.75	2.33	3.00
2	2.10	3.13	4.38	6.21
2 1/2	3.58	5.88	7.75	9.70
3	5.20	9.81	12.83	17.18
3 1/2	6.55	10.50	15.60	22.00
4	12.00	13.60	24.50	34.30
5	13.00	16.00	31.00	43.00
6	20.00	24.00	48.00	72.00
8	35.00	47.00	95.00	146.00
10	64.00	86.00	170.00	228.00
12	102.00	120.00	262.00	350.00
14	130.00	156.00	325.00	400.00
16	179.00	204.00	412.00	550.00
18	228.00	258.00	510.00	690.00
20	320.00	370.00	640.00	830.00
24	520.00	612.00	890.00	1,200.00

NOM PIPE SIZE	180° Returns - Short Radius			
	SCH. 5S	SCH. 10S	SCH. 40S	SCH. 80S
1/2	-	-	-	-
3/4	-	-	-	-
1	.32	.36	.46	.59
1 1/4	.44	.60	.78	1.03
1 1/2	.60	.84	1.12	1.50
2	.92	1.40	2.00	2.76
2 1/2	1.86	2.40	3.96	5.28
3	2.44	3.40	6.24	8.44
3 1/2	3.24	4.60	8.76	12.10
4	4.20	6.00	11.90	16.50
5	8.40	10.40	20.20	28.60
6	12.60	16.40	31.20	47.00
8	21.00	28.40	63.00	95.00
10	40.00	50.00	111.00	150.00
12	68.00	78.00	164.00	216.00
14	86.00	104.00	210.00	278.00
16	120.00	136.00	276.00	364.00
18	154.00	176.00	350.00	462.00
20	212.00	244.00	430.00	572.00
24	356.00	406.00	626.00	830.00

NOM PIPE SIZE	Reducers Concentric & Eccentric			
	SCH. 5S	SCH. 10S	SCH. 40S	SCH. 80S
1/2	.06	.09	.10	.11
3/4	.11	.12	.13	.14
1	.18	.19	.35	.29
1 1/4	.20	.28	.38	.39
1 1/2	.22	.31	.50	.54
2	.36	.38	.60	.75
2 1/2	.50	.56	1.00	1.12
3	.86	.88	1.56	1.87
3 1/2	1.20	1.25	2.25	2.50
4	1.25	1.44	2.69	3.54
5	2.00	2.25	4.06	5.63
6	2.75	3.00	7.12	10.00
8	4.50	5.50	12.50	16.38
10	9.50	10.80	20.30	27.30
12	14.00	14.40	28.80	36.60
14	17.00	18.00	35.70	48.00
16	30.00	32.00	48.50	65.00
18	38.00	39.60	59.40	79.20
20	55.00	60.00	75.00	88.00
24	75.00	76.00	98.00	135.00

Dunlap Stainless, Inc.

2905 Ramsey Road

Gainesville, GA 30507

(770) 531-1933 (Mon-Fri 8am-5pm)

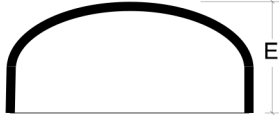

Cap

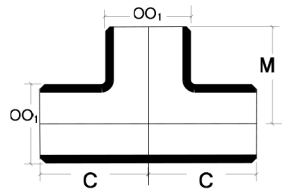

Straight Tee

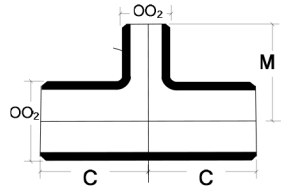

Reducing Tee

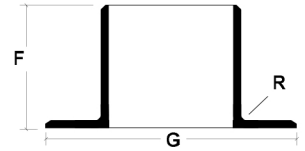

Short Pattern Stub End

NOM PIPE SIZE	Caps			
	SCH. 5S	SCH. 10S	SCH. 40S	SCH. 80S
1/2	.08	.09	.10	.11
3/4	.11	.12	.13	.14
1	.18	.19	.35	.29
1 1/4	.20	.28	.38	.39
1 1/2	.22	.31	.50	.54
2	.36	.38	.60	.75
2 1/2	.50	.56	1.00	1.12
3	.86	.88	1.56	1.87
3 1/2	1.20	1.25	2.25	2.50
4	1.25	1.44	2.69	3.54
5	2.00	2.25	4.06	5.63
6	2.75	3.00	7.12	10.00
8	4.50	5.50	12.50	16.38
10	9.50	10.80	20.30	27.30
12	14.00	14.40	28.80	36.60
14	17.00	18.00	35.70	48.00
16	30.00	32.00	48.50	65.00
18	38.00	39.60	59.40	79.20
20	55.00	60.00	75.00	88.00
24	75.00	76.00	98.00	135.00

NOM PIPE SIZE	Tees - Straight & Reducing			
	SCH. 5S	SCH. 10S	SCH. 40S	SCH. 80S
1/2	.19	.21	.23	.30
3/4	.22	.28	.38	.45
1	.40	.63	.65	.85
1 1/4	.75	1.10	1.31	1.50
1 1/2	.95	1.50	1.90	2.25
2	1.20	1.87	2.83	3.50
2 1/2	2.15	3.10	4.85	6.90
3	3.40	3.90	7.30	9.80
3 1/2	5.50	5.88	9.00	12.00
4	7.20	7.63	11.63	17.00
5	13.00	13.45	20.75	25.00
6	17.20	17.80	24.25	30.00
8	31.00	34.50	46.10	62.00
10	55.00	59.00	78.00	110.00
12	83.00	87.00	137.00	185.00
14	89.00	107.00	175.00	210.00
16	115.00	130.00	220.00	344.00
18	149.00	169.00	286.00	344.00
20	171.00	228.00	358.00	430.00
24	298.00	343.00	498.00	600.00

NOM PIPE SIZE	Stub Ends		
	SCH. 5S	SCH. 10S	SCH. 40S
1/2	.14	.16	.19
3/4	.18	.21	.26
1	.25	.35	.38
1 1/4	.39	.49	.55
1 1/2	.41	.56	.69
2	.71	.94	1.35
2 1/2	.95	1.25	1.77
3	1.23	1.60	2.50
3 1/2	1.63	1.90	3.58
4	1.90	2.40	4.13
5	2.80	3.25	6.15
6	3.88	4.75	7.88
8	5.90	7.10	13.38
10	8.90	11.30	22.20
12	15.30	18.00	31.50
14	19.00	24.00	37.80
16	25.00	28.00	45.00
18	34.00	38.00	60.00
20	43.00	48.00	66.00
24	57.00	60.00	85.00